

ARLINGTON COUNTY

BIKE PARKING STANDARDS GUIDE



2022
UPDATE

TABLE OF CONTENTS

- INTRODUCTION.....2
- CLASSES OF BIKE PARKING.....3
 - Class 1
 - Class 2
 - Class 3
- CLASS 1 BIKE PARKING REQUIREMENTS4
 - General Requirements
 - Preferred Location Options
 - Additional Location Options
 - Design Requirements
 - Approvable Class 1 Bicycle Rack Options and Specifications
 - Shower and Locker Facility Requirements
- CLASS 3 BIKE PARKING.....7
 - General Requirements
 - Approvable Class 3 Bicycle Rack Specifications
 - Class 3 Layout and Installation
 - 1. In-Ground Mount (Preferred Method)
 - 2. Flange (Surface) Mount
 - 3. Rack installation on a sloped sidewalk
- PLAN REQUIREMENTS.....9
 - Step by Step Guide to Bicycle Parking in Renovation or Retrofit Process
 - Class 1 Plan Requirements
 - Architectural plans: Interior bike rack locations
 - Enlarged architectural plans: Interior bike rack details
 - Class 3 Plan Requirements
 - Civil/Landscape Plans
- APPENDIX.....12
 - Contact for More Information
 - County Technical Specification Sheets

INTRODUCTION

This guide is designed to give developers, architects, property managers, construction professionals, and County staff the knowledge to design, install, and maintain great bicycle parking facilities. This guide outlines the current County design and installation standards and procedures for secure and visitor bicycle parking in both new and retrofitted construction. It is the property owner's responsibility to keep these bicycle facilities well maintained and useful for tenants and residents. These high-quality facilities promote and encourage bicycling as an efficient and convenient form of transportation for residents, workers, and visitors to Arlington County.



Fully enclosed room in garage with double-decker racks

CLASSES OF BIKE PARKING

Class 1

Class 1 bike parking refers to secure bicycle storage facilities that are intended for all-day or overnight storage. These are typically provided for employees in commercial buildings or residents and regular employees in multi-family residential properties. Class 1 facilities are characterized by protection from the weather and protection from theft via a locked, enclosed room. In commercial properties, Class 1 bike parking requirements may also include shower and locker facilities to serve bike commuters.

Class 2

Class 2 bicycle parking refers to bicycle storage facilities that are covered or shielded from the elements, but are not within a locked, enclosed room. These are often found near garage entrances, or elevators or stairwells. They count towards a building's nonsecure visitor bike parking spaces when measured for Site Plans compliance purposes. They will not receive a chapter in this bike parking standards guide.

Class 3

Class 3 bicycle parking refers to short term bicycle parking intended for visitors to an establishment. This parking is outdoors and uncovered. While this type of parking is exposed to the elements, it is meant to be convenient for visitors and customers who intend to stay a brief amount of time.

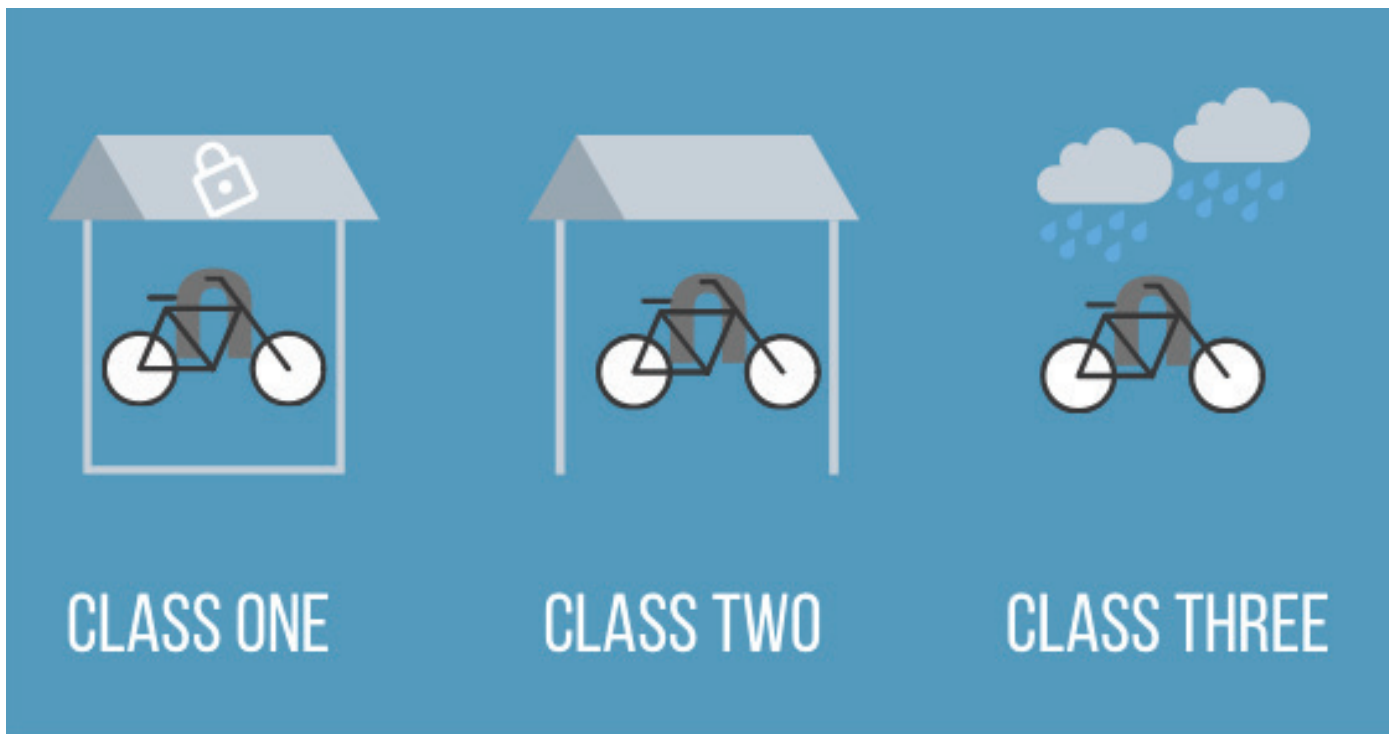

Mobility Lab

Approvable Bike Racks

Here is a link to a non-exhaustive [list of approvable bike racks](#). Staff reserves the right to not approve a rack model on this list based on site design context, changes to rack design/finish by the vendor, or other considerations.

CLASS 1 BIKE PARKING REQUIREMENTS

General Requirements

- Protection from weather
- Security of locked room or cage
- Ability to lock bicycle to a rack within the room or cage

Preferred Location Options

- Fully enclosed ground floor room with direct sidewalk access
Clean, efficient to access, highly secure, less conflict with cars



Fully enclosed bike room with direct street access



Cage in garage with horizontal racks

Additional Location Options

- Fully enclosed room in garage
Discrete, highly secure; however, can conflict with cars and be less inviting for users
- Cage in a garage
Secure; however, conflicts with cars, can appear less clean and inviting, and bikes are visible to potential thieves
- Bike lockers (for unique scenarios)
Secure; however, not space-efficient and if placed outdoors, bicycle riders are not protected from the weather

Design Requirements

- At least 30% of bicycle parking must be horizontal and at floor level
- Doors must be hollow metal
- Doors must use a heavy-duty cipher lock or electronic lock
- For cages only:
 - o Hollow metal doors still required, but cage walls may need to be supplemented by sheet metal plating (3 feet in each direction) as needed to prevent tampering with door handle or lock
 - o Cage walls must be made of industrial grade expanded metal or welded wire mesh; other acceptable wall materials are concrete block and drywall
 - o Cage walls must reach all the way from floor to ceiling (not drop ceiling)

Approvable Class 1 Bicycle Rack Options and Specifications

- Standard inverted-U or hoop racks for surface mount to floor.
- Vertical racks on walls or freestanding frames
- “Double decker” racks for more efficient use of extra vertical space

Access a non-exhaustive [list of approvable bike racks](#).

MINIMUM CLEARANCES

5 FT

MINIMUM
CLEARANCE

Aisle width – single
level

7 FT

MINIMUM
CLEARANCE

Aisle width
double-decker
racks

3 FT

MINIMUM
CLEARANCE

Perpendicular on-center
distance between parallel
or angled hoop racks

8 FT

MINIMUM
CLEARANCE

Distance between
end to end U racks

2 FT

MINIMUM
CLEARANCE

Distance from any
obstruction

See specific
manufacturer's
specs

MINIMUM
CLEARANCE

Vertical clearance
for hanging or
double-decker rack

Note: For complete installation, dimensions, and hardware details of bike racks, please reference “General Notes for Bicycle Rack Installation” Drawings R8.0 – R8.3 in the Appendix.

Shower and Locker Facility Requirements

Showers and lockers complement Class 1 bike parking for bicycle commuters by providing dedicated space for riders to clean up before the workday and to store things such as clothes or toiletries rather than traveling back and forth with these items.

- Shower and locker facilities should be accessible for storage 24/7, and at a minimum should be accessible for active use during normal business hours
- Lockers should be provided within the secure bike parking area or nearby locker room and located adjacent to shower facilities
- If lockers are provided in separate gender locker rooms, each room needs to have the required number of lockers (not split between the two)
- The minimum acceptable locker dimensions are 12" wide, 18" deep, 36" tall



Shower and locker facility



Shower and locker facility



Shower and locker facility

CLASS 3 BIKE PARKING

General Requirements

- Installed within 50 feet of a main entrance
- Leaves pedestrian paths and vehicle rights-of-way clear
- Highly visible
- Other considerations:
 - Often placed in “landscape zone” in line with tree pits, benches, lamp posts, etc.
 - Achieves “Class 2” status when covered by roof or overhang, which protects the rider and the bicycle from precipitation

Approvable Class 3 Bicycle Rack Specifications

- At least 18” wide and 33” tall when installed
- Secure anchor to a solid, immovable surface
- Provides two points of contact for typical adult or child’s bicycle frame
- Allows user to lock frame and one wheel to rack using standard U-lock
- Constructed of 2” Nom. (2.38” O.D.) Sch. 40 or 2” square steel pipe
- Approvable outdoor finishes include hot-dip galvanized, thermoplastic, or stainless steel
- See Appendix for County Construction Specifications

Class 3 Layout and Installation

Here is an overview of approvable options for Class 3 layout and installation. For detailed information on installation requirements, please see County specifications in the Appendix.



In-ground mount



Flange (surface) mount and tamper resistant nuts

1. In-Ground Mount (Preferred Method)

- Legs must be anchored 9” deep in new concrete within minimum dimensions, including a minimum of 3” of concrete encasement on all sides
- Legs must be fitted with anchor pins to prevent lift-out

2. Flange (Surface) Mount

- Must be installed on cured concrete sidewalk or continuous concrete subbase
- Legs must have a minimum of two fasteners per flange
- Concrete sidewalk must be minimum 4” thick and conform to County sidewalk standard
- Anchors must be friction, mechanically expanded, or adhesive bonded, and may be threaded or driven; if threaded, they must be fixed with tamper-resistant nuts as approved by the County
- Rack may not be bolted to unit pavers; however, unit pavers may be installed over flanges mounted to concrete
 - Pavers must be neatly cut and fit around flanges, fasteners, and legs of rack while maintaining the minimum height from finished grade

3. Rack Installation on a Sloped Sidewalk

- Ensure the legs of the rack are vertical (plumb) in two planes
- Preferred method is using in-ground racks
- For surface-mounted racks, the use of shims may accomplish this task

2 FT

MINIMUM
CLEARANCE

Distance from any
obstruction

3 FT

MINIMUM
CLEARANCE

Perpendicular on-center
distance between
parallel or angled racks

8 FT

MINIMUM
CLEARANCE

Distance between
end to end U racks

Note: for complete installation, dimensions, and hardware details of bike racks, please reference "General Notes for Bicycle Rack Installation" Drawings R8.0 – R8.3 in the Appendix.



Sloped sidewalk installation

PLAN REQUIREMENTS

Step by Step Guide to Bicycle Parking in Renovation or Retrofit Process

1. Obtain copy of relevant plan sheets for area on property where bike rack installation is to be considered.
2. Schedule site selection meeting with TDM staff for location and layout guidance and troubleshooting.
3. Submit drafts of revised plan and detail drawings to TDM staff for review.

4. Submit approvable drawings as a part of application for administrative change (contact Zoning for determination if administrative change is necessary).
5. If administrative change is approved, order materials.
6. Schedule installation coordination meeting with TDM staff prior to install for layout guidance and troubleshooting.
7. Complete installation.
8. Schedule inspection of installation with TDM staff.

Class 1 Plan Requirements

Architectural plans: Interior bike rack locations

1. Show and label all interior bike parking locations on appropriate architectural floor plan.

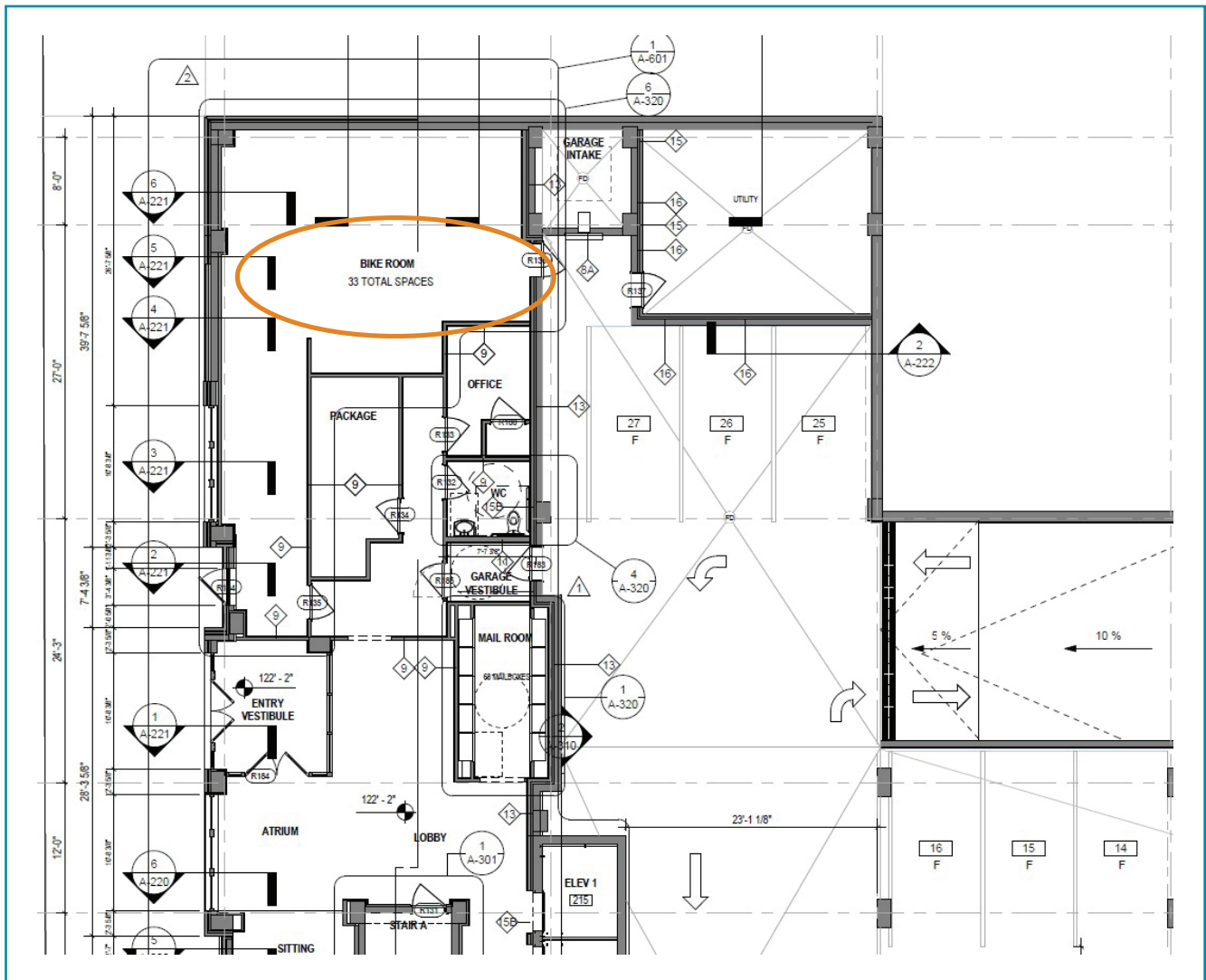

Enlarged architectural plans: Interior bike rack details

Show and label the following:

- Proposed room or cage walls
 - Wall and door material
 - Cage wall and/or door security plates (if applicable)
 - Door lock type
 - Dimensions between racks
 - Dimensions from racks to walls and other obstructions
 - Aisle widths
- For each type of bicycle rack—provide a construction specification sheet with information from the manufacturer and hardware schedule
 - Include County technical specification sheets R8.0-R8.3
 - Where needed for clarity for vertical and double-decker rack installations, there should be a drawing depicting sufficient ceiling clearance above the racks

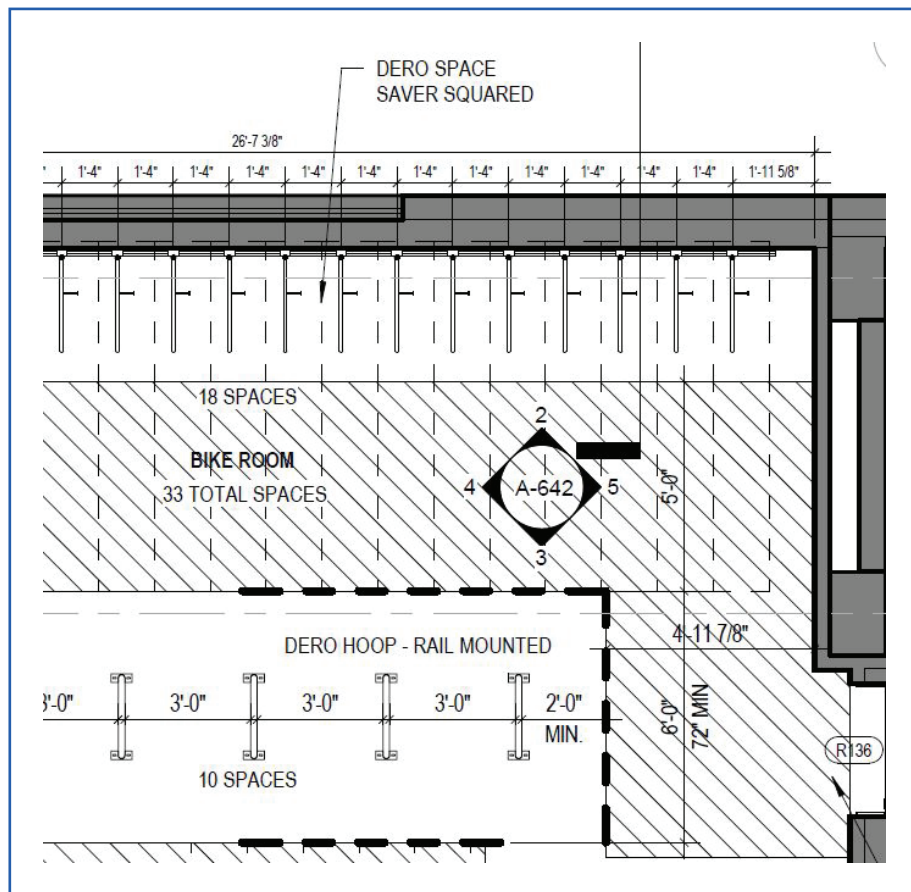

Advisable for Larger Buildings

- Include a table that shows the total number of bike parking spaces provided and broken out by room and floor
- Label each bike room with the total number of bike racks in the room

Class 3 Plan Requirements

Civil/Landscape Plans

Site or Streetscape Plan Sheet

1. Show and label all exterior bike parking locations. Must be able to count number of spaces in design.

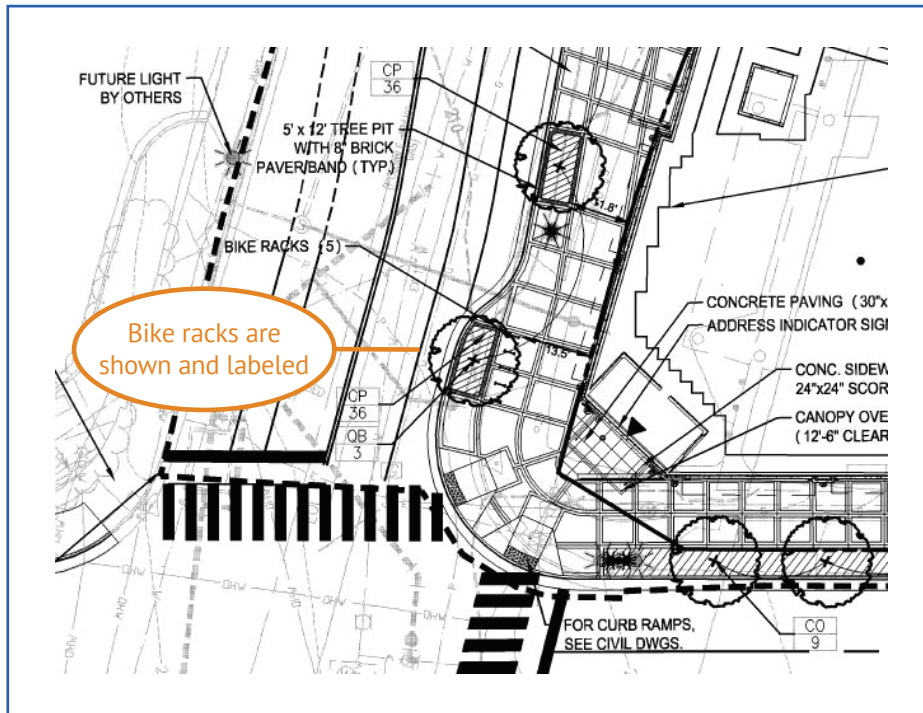

Detail Drawings

1. Show and label distance between racks and all obstructions.
2. For each type of bicycle rack—provide a construction specification sheet with information from the manufacturer and hardware schedule.
3. Include County technical specification sheets R8.0-R8.3.

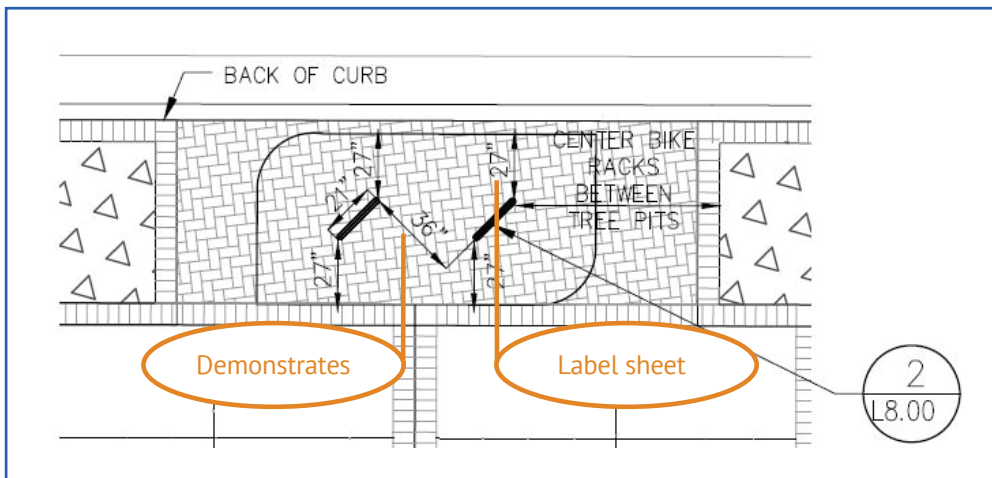

Civil and Landscape Plans Must Match



APPENDIX

Contact for More Information

TDM Research and Site Plan Development Manager

Eric Balliet | w: 703.228.3770

eballiet@arlingtonva.us



County Technical Specification Sheets

NOTES:

GENERAL:

1. THIS TECHNICAL SPECIFICATION IS INCLUDED BY REFERENCE IN THE [ARLINGTON COUNTY BICYCLE PARKING STANDARDS](#).
2. BICYCLE RACKS SHALL BE OF AN ACCEPTED DESIGN THAT PROVIDES TWO POINTS OF CONTACT WITH A PARKED BICYCLE. INVERTED "U" RACKS AND OTHER DESIGNS CONSTRUCTED OF TUBING SHALL BE 2" NOM. (2.38" O.D.) SCH. 40 STEEL PIPE AS PER ASTM A53, OR 2" SQUARE SECTION 8 GAUGE AS PER ASTM A-500.
3. TOP OF INSTALLED BICYCLE RACKS SHALL BE MINIMUM 33" ABOVE FINISHED GRADE.
4. BICYCLE RACKS SHALL BE INSTALLED USING THE FOLLOWING OPTIONS ONLY:
 - a. FLANGE-MOUNTED TO CURED CONCRETE
 - b. IN-GROUND (ANCHORED IN NEW CONCRETE)
 - c. MOUNTED ON RAILS MOUNTED TO CURED CONCRETE OR ASPHALT
5. IF MULTIPLE RACKS ARE INSTALLED, THEY SHALL BE UNIFORMLY ALIGNED, AND EVENLY SPACED. FOR LAYOUT PURPOSES, EACH BICYCLE RACK SHALL BE CENTERED IN A "DESIGN STALL" OF MINIMUM DIMENSION 36" X 72".
6. ACCEPTABLE MATERIALS AND COATINGS. PIPE (AND FLANGES, RAILS, ANCHOR PINS, SHIMS, AND FASTENERS, IF APPLICABLE) SHALL BE HOT-DIP GALVANIZED (HDG) AS PER ASTM A123 AND A304; OR STAINLESS STEEL AS PER ASTM A666 AND A240. BICYCLE RACKS MAY BE POWDER COATED OVER HDG AS PER ASTM D 7803, OR THERMOPLASTIC COATED AS APPROVED BY THE COUNTY. COATING MUST BE COMPLETE, I.E., DIPPED OR COMPLETELY POWDER COATED.
7. BICYCLE RACKS SHALL BE ANCHORED FIRMLY, AND INSTALLED VERTICAL (PLUMB) IN TWO PLANES.
8. NO COMPONENT OF THE INSTALLED BICYCLE RACK SHALL RESULT IN A TRIPPING HAZARD.
9. BICYCLE RACKS SHALL NOT BE MOUNTED DIRECTLY TO UNIT PAVERS ONLY.
10. FASTENERS WHEN USED SHALL:
 - a. BE OF ACCEPTABLE MATERIAL AND COATING.
 - b. MEET ONE OF THE FOLLOWING REQUIREMENTS

TYPE	SPECIFICATION	MINIMUM SIZE	MINIMUM INSTALLATION DEPTH	ACCEPTABLE EMBEDMENT MATERIAL
THREADED	ASME B18.18:2017	3/8"	AS NECESSARY	METAL TO METAL. TAMPER RESISTANT NUTS REQUIRED.
FRICTION	A-A-1925a, ASTM E 488	3/8"	3"	CONCRETE
MECHANICALLY EXPANDED	A-A-55614, ASTM E 488	3/8"	3.5"	CONCRETE
ADHESIVE BONDED	ASTM C 881, ASTM E1512	3/8"	6"	CONCRETE, ASPHALT

- c. BE ABLE TO PROVIDE FIRM, SECURE ANCHORING WITH A MAXIMUM OF 1/4-INCH NON-TRIP HAZARD PROJECTION ABOVE FINISHED GRADE.
- d. BE THREADED OR DRIVEN ANCHORS. THREADED FASTENERS TO BE FIXED WITH TAMPER-RESISTANT NUTS AS APPROVED BY THE COUNTY.

GENERAL NOTES FOR BICYCLE RACK INSTALLATION

REVISION & DATE



ARLINGTON COUNTY, VIRGINIA
DEPARTMENT OF ENVIRONMENTAL SERVICES

DRAWING NO.
R-8.0

NOTES:

FLANGE MOUNTED INSTALLATION:

1. FLANGE MOUNTED RACKS SHALL BE INSTALLED ON EXISTING CURED CONCRETE. USE FLANGE RACKS WITH FASTENERS AS SPECIFIED ABOVE. EXISTING CONCRETE SHALL CONFORM TO CONCRETE SIDEWALK STD., ARLINGTON COUNTY CONSTRUCTION SPECIFICATION SECTION 02611, AND STD. DWG. R-2.0 (MIN. 4" THICKNESS).
2. RACK LEGS SHALL BE WELDED TO FLANGES WITH COMPLETE SEAMLESS CONTINUOUS FILLET WELDS CONFORMING TO ASTM A36, ASTM A312, AND AWS D1.1. SPOT, TACK, OR INTERMITTENT WELDING IS NOT ACCEPTABLE.
3. FLANGES SHALL BE MINIMUM 3/8" THICK, WITH MINIMUM TWO 1/2" DIA. HOLES (TWO FASTENERS) PER FLANGE.
4. FLANGE MOUNTED RACKS SHALL NOT BE BOLTED TO UNIT PAVERS.
5. WHERE CONCRETE PAVERS OR FIRED CLAY BRICK ARE INSTALLED OVER CONTINUOUS CONCRETE SUB-BASE, FLANGE-MOUNTED RACKS SHALL BE INSTALLED ON CONCRETE SUB-BASE. INSTALLATION MUST NOT COMPROMISE ANY WATERPROOFING OF CONCRETE. (FOR EXAMPLE, INSTALLATION ABOVE UNDERGROUND PARKING STRUCTURE.)
6. UNIT PAVERS SHALL BE INSTALLED IN ACCORDANCE WITH ARLINGTON COUNTY CONSTRUCTION SPECIFICATION SECTION 02612.
7. UNIT PAVERS SHALL BE NEATLY CUT AND FIT AROUND FLANGES, FASTENERS, AND LEGS OF RACK.
8. LEGS OF FLANGE MOUNTED RACKS SHALL BE OF SUFFICIENT LENGTH TO PROVIDE MINIMUM ACCEPTABLE HEIGHT OF 33" ABOVE FINISH GRADE.

IN-GROUND RACK INSTALLATION:

1. LEGS OF IN-GROUND RACKS SHALL BE FITTED WITH ANCHOR PINS TO PREVENT LIFT-OUT. ANCHOR PINS SHALL BE:
 - a. OF ACCEPTABLE MATERIAL.
 - b. MIN. 3/8" DIAMETER WITH MIN. 3" CONCRETE ENCASEMENT.
2. IN-GROUND RACKS SHALL BE INSTALLED AND FIRMLY ANCHORED IN NEW CONCRETE OF MINIMUM DIMENSIONS SHOWN. ANCHORED PORTIONS OF RACK SHALL HAVE MIN. 3" CONCRETE ENCASEMENT ON ALL SIDES.
3. FOR RACK INSTALLATIONS ON SITES WITH CONCRETE PAVERS OR FIRED CLAY BRICK INSTALLED OVER COMPACTED SOIL SUB-BASE AND SAND LEVELING COURSE AS PER ARLINGTON COUNTY STANDARD SPECIFICATIONS SECTION 02612, AND STANDARD DWG. R-2.1, RACKS SHALL BE INSTALLED IN CONCRETE FOOTING OF DIMENSIONS SHOWN.
4. WHERE IN-GROUND RACKS ARE INSTALLED IN UNPAVED SOIL, OR SOD/GRASS/TURF, PROVIDE A SINGLE CONCRETE FOOTING OF DIMENSIONS SHOWN. PROVIDE A TAMPED GRAVEL PAD MIN. 4" THICKNESS, AND MIN. 36" X 72" CENTERED ON EACH INSTALLED RACK.
5. LEGS OF IN-GROUND RACKS SHALL BE OF SUFFICIENT LENGTH TO PROVIDE ANCHORING BELOW GRADE A MINIMUM OF 9" AND BE A MINIMUM HEIGHT OF 33" ABOVE FINISH GRADE.

INSTALLATION ON RAILS:

1. BICYCLE RACKS MAY BE APPROVED IN "GANGED" ASSEMBLIES OF FROM 2 TO 7 RACKS ON CONTINUOUS RAILS.
2. RAILS SHALL BE TYPE AISI C3 X 4.1 STEEL CHANNEL AS PER ASTM A36, HDG, OR POWDER COATED OVER HDG TO MATCH RACKS.
3. INDIVIDUAL RACKS CAN BE WELDED TO RAILS. WELDS SHALL BE COMPLETE SEAMLESS CONTINUOUS FILLET WELDS CONFORMING TO ASTM A36, ASTM A312 AND AWS D1.1. SPOT, TACK, OR INTERMITTENT WELDING IS NOT ACCEPTABLE.
4. INDIVIDUAL RACKS CAN BE BOLTED TO RAILS.
5. IF RACKS ARE BOLTED TO RAILS, FASTENERS SHALL BE:
 - a. OF ACCEPTABLE MATERIAL.
 - b. MIN. 3/8" DIAMETER.
 - c. ABLE TO PROVIDE FIRM, SECURE ANCHORING WITH THREADED NUTS ON UNDERSIDE OF STEEL CHANNEL.
 - d. FITTED WITH TAMPER- RESISTANT THREADED NUTS AS APPROVED BY THE COUNTY.
6. RACKS ON RAILS MAY BE APPROVED FOR INSTALLATION ON FINISHED ASPHALT. IN SUCH CASES, A PERMANENTLY GROUTED, INTERNALLY THREADED ASPHALT ANCHOR AS APPROVED BY THE COUNTY SHALL BE USED TO PROVIDE ATTACHMENT.

SITE APPLICATION NOTES FOR BICYCLE RACK INSTALLATION

REVISION & DATE



ARLINGTON COUNTY, VIRGINIA
DEPARTMENT OF ENVIRONMENTAL SERVICES

DRAWING NO.
R-8.1

NOTES:

1. FOR LAYOUT PURPOSES, EACH BICYCLE RACK SHALL BE CENTERED IN A "STALL" OF MINIMUM DIMENSION 36" X 72".
2. IF MULTIPLE RACKS ARE ANGLED OR SKEWED, CENTER-TO-CENTER SEPARATION BETWEEN PARALLEL RACKS MUST BE INCREASED TO MAINTAIN THE MINIMUM 36" X 72" CLEAR "STALL" AREA AT EACH RACK.
3. MINIMUM 24" CLEARANCE IS NEEDED FROM WALL OR OTHER OBSTRUCTIONS.

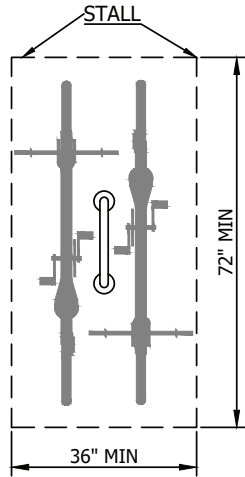

SINGLE RACK

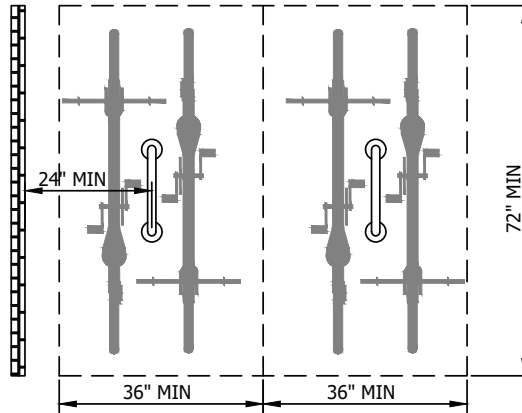

SIDE BY SIDE RACKS

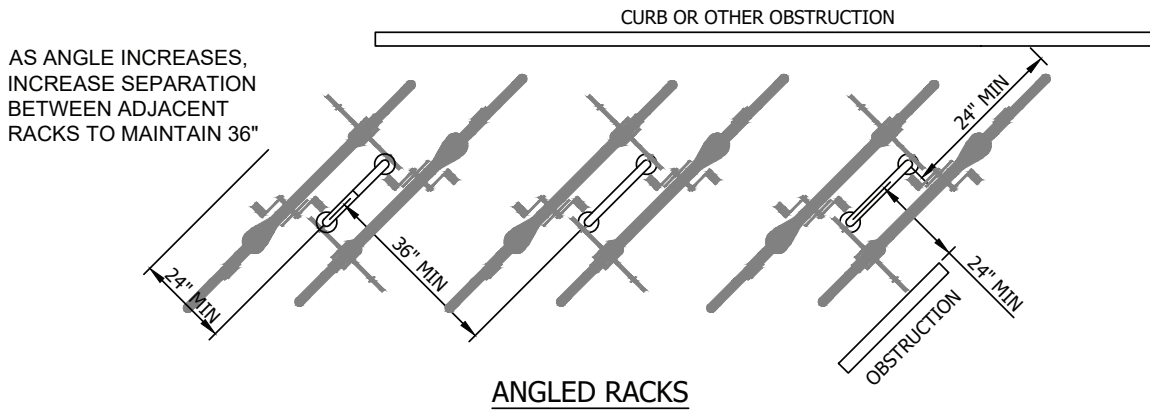

ANGLED RACKS

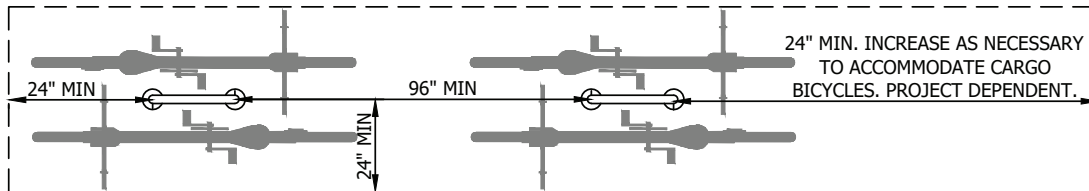

END TO END RACKS

BICYCLE RACK LAYOUT

REVISION & DATE



ARLINGTON COUNTY, VIRGINIA
DEPARTMENT OF ENVIRONMENTAL SERVICES

DRAWING NO.
R-8.2

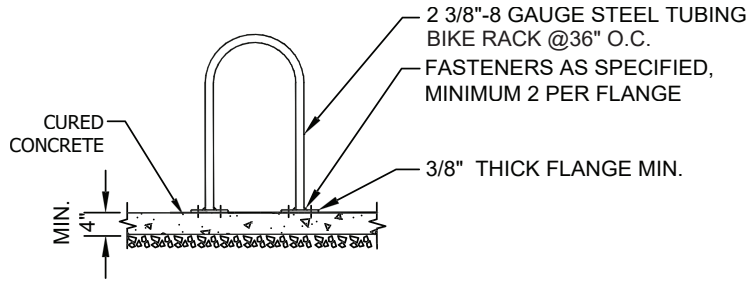

**FLANGE MOUNT FLUSH
(TYPICAL INSTALLATION)**

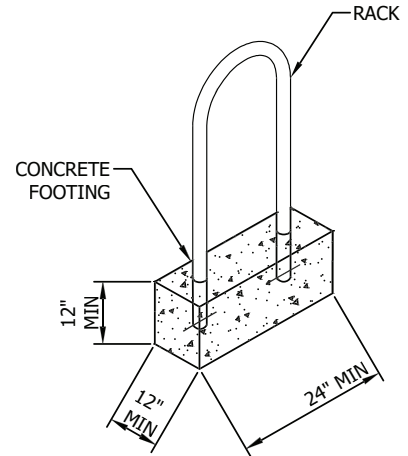
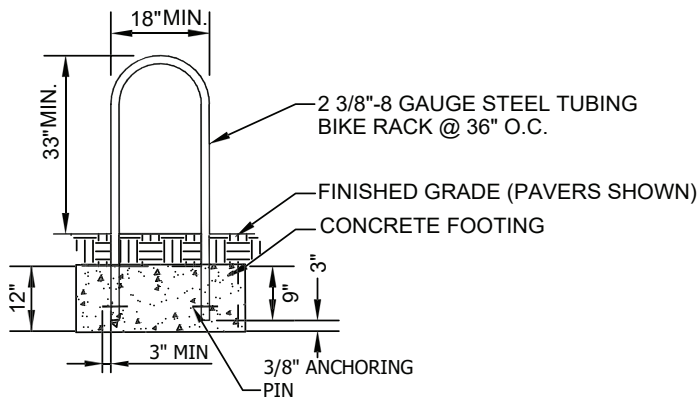

IN-GROUND RACK INSTALLATION

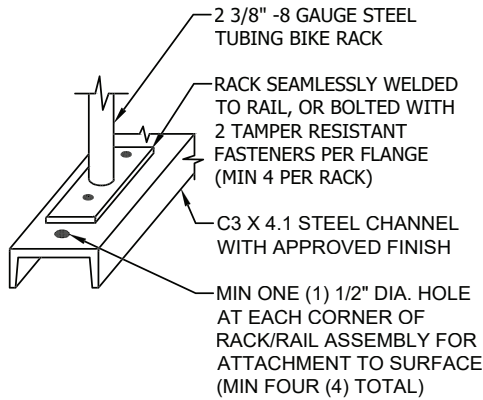

INSTALLATION ON RAILS

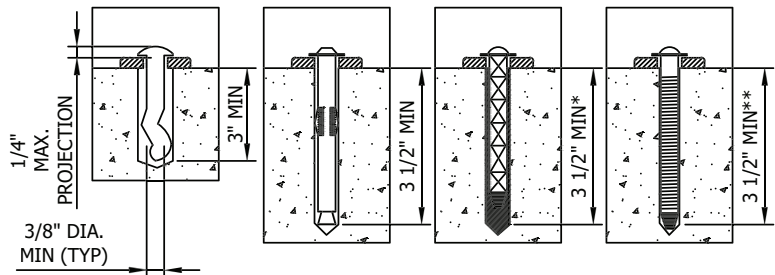

ANCHOR DETAILS

* MIN 3 1/2" FOR ADHESIVE BONDED ANCHOR IN CONCRETE. MIN 6" FOR ADHESIVE BONDED ANCHOR IN ASPHALT.

**THREADED FASTENERS IN CONCRETE SHALL BE TYPE 316 AND TYPE 304 STAINLESS STEEL WITH CARBON-STEEL LEAD THREADS

BICYCLE RACK INSTALLATION



ARLINGTON COUNTY, VIRGINIA
DEPARTMENT OF ENVIRONMENTAL SERVICES

ISSUED 7/1/2020

DRAWING NO.
R-8.3

